



# DMC05 E, DMA05 E

## Waterproof Manual call points

- **DMC05 E: Conventional manual call point Resettable**
- **DMA05 E: Addressable manual call point Resettable**
- **EN54-11 Ed 2001**

**DMC05 E and DMA05 E** waterproof conventional and addressable manual call points. are devices of transmission of an **alarm** status towards a conventional or addressable indicating panel. This action is carried out by the operator through mechanical pressure on the window located in the front. Return to the normal.

**DMC05 E, DMA05 E** particularity is its IP protection equal to **IK08** allowing the use of the device on **outdoors conditions**.

The 2 references are **conform with the EN54-11** and with **EN54-17 for addressable version** for the use of **embedded isolator**.

Manual call point activated alarm status can be resettled **with the use of a special key**.



### Main characteristics

- EN54-11
- EN54-17, for use of isolator in addressable version
- IP protection IK08
- No break glass
- Resettable with key

<b>Power supply specification</b>		
	<b>DMC05 E</b>	<b>DMA05 E</b>
Main supply voltage	13 Vdc to 30 Vdc	12Vdc to 28Vd
Nominal main supply voltage	20 Vdc	24 Vdc
Quiescent current	< 10 $\mu$ A	150 $\mu$ A with closed isolator 500 $\mu$ A with opened isolator
Alarm current	35 mA +/- 2mA	5mA +/- 1mA
<b>Mechanical characteristics</b>		
Unit weight	300g	
Unit dimensions (in mm)	120 x 120 x 87	
Unit row material	ABS	
Unit colour	Red	
Protection class	IK08	
<b>Climatic characteristics</b>		
Operating temperature	-25°C to +70°C	
Storage temperature	+10°C to +50°C	
Operating relative humidity	≤ 95%	
Storage relative humidity	≤ 85%	



# DMC05 E, DMA05 E

## Waterproof Manual call points

### DMC05 E connection diagram

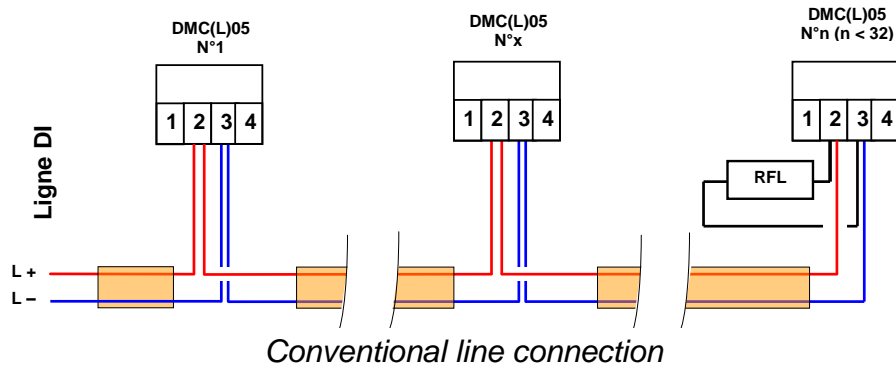

### DMA05 E connection diagram

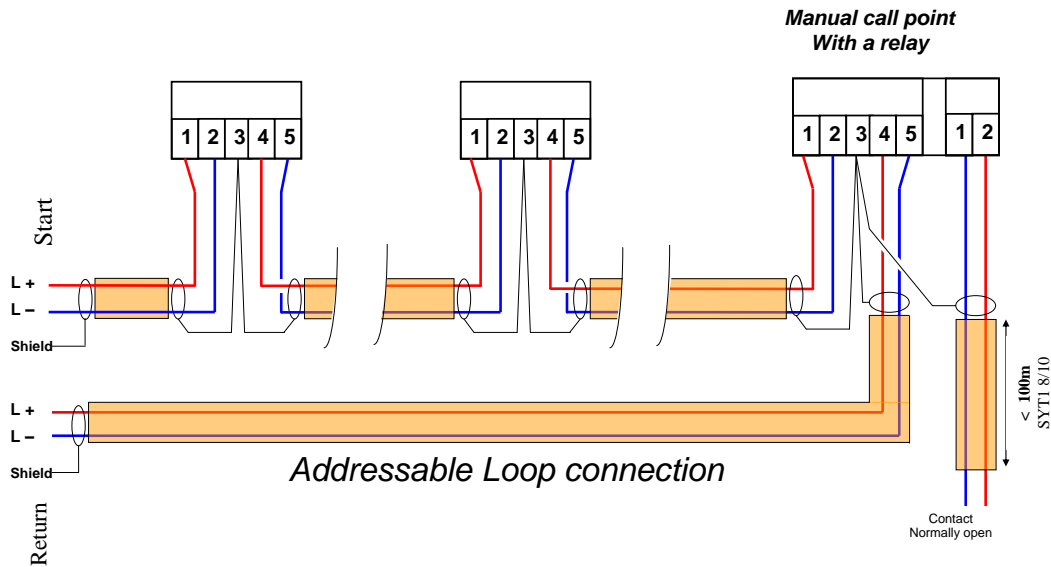

#### REFERENCE

#### DESCRIPTION

- |         |   |
|---------|---|
| DMC05 E | Conventional WATERPROOF Manual call point resettable with key without breaking glass, Led and alarm resistor integrated, EN54-11, CE according to CPD         |
| DMA05 E | Addressable WATERPROOF Manual call point resettable with key without breaking glass, Led and alarm resistor integrated, EN54-11, EN54-17, CE according to CPD |

